



Made of the highest quality materials, the Ellipse Single Arm Casement Operator has provided years of continuous and trouble-free service for our customers. This operator will provide a full 90° window opening and disconnects easily from the sash. Nylon roller runs in the steel track to further assure smooth operation. Concealed mounting screws produce a neat overall appearance.

SEALABLE CASE: The unique case design complements the smooth contour styling of the Maxim® family of products, while retaining the same mounting and mechanical features of Truth's Traditional Operator lines. A special "lip" around the operators' case will accept a gasket, which will help the window achieve a higher air and water performance rating, while at the same time; eliminate the need for slow, messy and often expensive caulking during the installation process.

LOGO OPTIONS: Have you considered *personalizing* your window with your company name or logo? All of Truth's operator handles are capable of accepting your own "signature". Contact Truth for further details.

WARRANTY: Protected under the terms of the Truth Warranty for Window & Door Manufacturers & Authorized Distributors. Refer to Truth's Terms & Conditions for further details.

CORROSION RESISTANCE: Truth's E-Gard® Hardware has a multi-stage coating process that produces a superior physical and aesthetic finish. Plus, it is resistant to a wider range of corrosive materials, including industrial cleaning materials and environmental pollutants. This proprietary process has been tested to be approximately three times better than common zinc plated finishes.

For the severe conditions associated with coastal areas, Truth has developed certain product lines utilizing either CoastGard® Hardware, or stainless steel hardware. See Tech Note #7 for further information about corrosion protection and these special hardware options.

MATERIAL: High-pressure die-cast zinc case, crank handle and knob. Hardened steel drive worm and gear arm with nylon roller. Track available in steel or 300 Series stainless steel.



FINISH: Electrostatically applied, durable coatings that provide excellent resistance to chipping, scratching and corrosion while maintaining color stability for years in direct sunlight. Please refer to Truth's Color Chart for examples of Truth's most popular finish options. Truth also offers a wide range of decorative "plated" finishes - contact Truth for additional information on availability of these finishes on specific product lines.

ORDERING INFORMATION:

1. Choose operator model desired (see table in Fig. 3 for options).
2. Specify Ellipse style housing.
3. Specify finish number.
4. Specify right- or left-hand (determined by the side the hinge is on when viewed from the outside).
5. Select mounting hardware (sold separately):
 #11454.XX - Contour™ Handle - shown above (painted) or
 #11329.XX - Folding Handle (painted)
 #30706.92 - Face-mount track (3-hole)
Optional track for special profile applications - see Brackets & Track Section.
 #21306 - Protective red plastic spline cap (optional)
 #21504 - Ellipse Gasket (optional)
 #21494 - Gasket Applicator (optional)

RECOMMENDED SCREWS:

Types of screws required determined by material of profile used. Refer to drawings for complete information on screw type and quantity needed (sold separately). For additional information regarding screw selection-see Truth Tips and Tech Note #11.

TRUTH TIPS:

1. Operator handing is determined by the hinge side when viewed from the outside.
2. Before selecting an operator, the hinge model should be chosen based upon desired window hinging requirements (example: egress vs. washability).
3. Sash weight should be limited to 40 lbs. to insure ease of operation for the lifetime of the window. When used on a sash weighing over 40 lbs., operating torque will noticeably increase and operator life will be reduced.
4. Operator torque can be kept to a minimum by using the longest possible arm that will fit between the side jambs.
5. Recommended range for Dimension "X" is .250" (6.4 mm) to 1.000" (25.4 mm).
6. Selecting the longest operator arm possible and minimizing dimensions "X" and "C" will result in best operator performance.

7. Arm lengths shorter than 9.5" will not allow easy operation of a window to 90° unless used with Truth's #14.77 hinge.

8. When used in high rise applications of over two stories, Truth recommends using a Limit Device (or see Tip 10).

9. For limited opening applications, Truth recommends using #31727 Track.

10. This operator may be mounted closer to the lock side of the window to effectively limit opening and improve corner pull-in performance.

11. A spline cap (#21306) is available to protect the operator splines from dirt and other windows from damage during shipping, installation, and final building construction.

12. Truth recommends that a Snubber be used at the center of the hinge side on any casement window which has a tendency to bow outwardly at the center in the closed position. Adding a Snubber may increase the negative air pressure rating of a casement window.

13. The Truth Single Arm Operator works well with a Butt Hinge. Always use an operator with the longest arm possible for best operation.

14. For accurate hardware placement in vinyl or metal applications, pre-drilling of the window profile is recommended.

15. For vinyl window applications, mounting screws should pass through two PVC walls, or one PVC wall and one insert wall. For this reason, it may be necessary to use a longer screw than is recommended.

16. For metal window profiles, Truth recommends machine screws. However, in most applications, sheet metal screws will provide adequate holding power.

17. When selecting mounting screws for Truth hardware, coating compatibility is one of the most important criteria. For best corrosion resistance the coating on the screws should be the same as the coating on the hardware. For more information see Tech Note #11.

18. Single Arm Operators do not work well with 4-Bar Hinges unless the 4-Bar Hinge is an egress hinge. If a 4-Bar Hinge other than an egress hinge is required, a Truth Dyad or Split Arm Operator is the best choice.

INCLUDE TRUTH SPECS ON YOUR NEXT WINDOW PROJECT

Window operators shall be provided which allow easy adjustment of window position. The mechanism should be crank operated and provide smooth operation of egress or butt hinges. Connection to the movable sash must be easily detachable for window cleaning and maintenance.

Window operators will be of single push arm design driven by a hand crank. The operator must be constructed of E-Gard® components, hardened steel worm and gear arm and high pressure zinc alloy die cast base.

Window Operators shall be 15 series Ellipse Single Arm Operator as manufactured by Truth Hardware, Owatonna, MN.

U. S. Patent #4,505,601

Canadian Patent #1,202,645

Other patents and patents pending worldwide

FIG. 1 APPLICATION OF TRUTH ELLIPSE SINGLE ARM OPERATOR

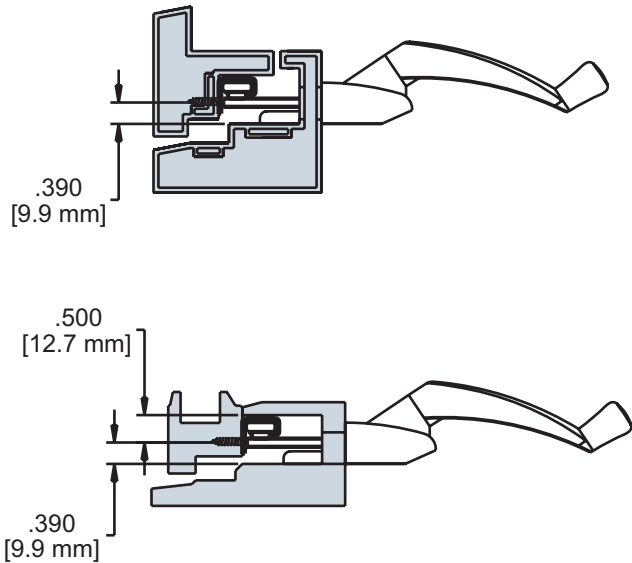
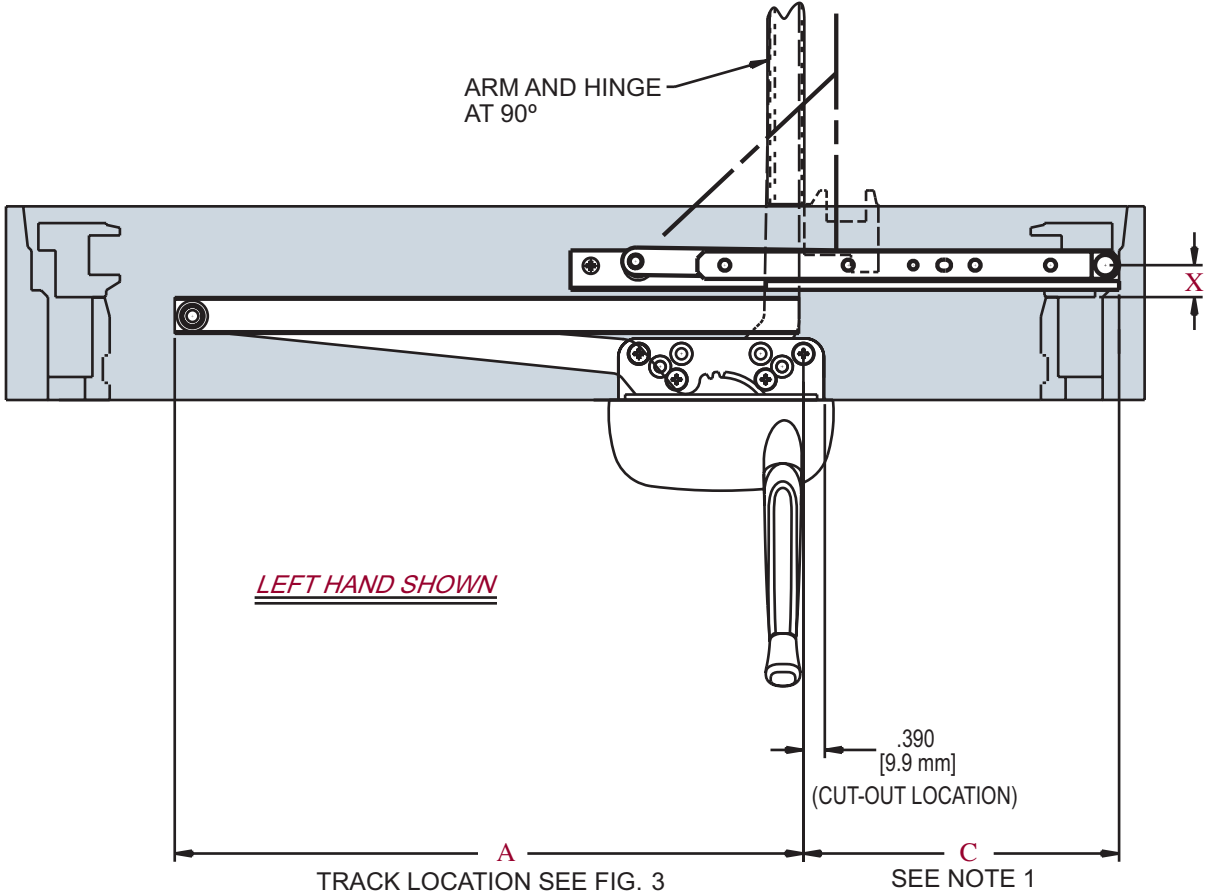

AVAILABLE HINGES	Y HINGE CONSTANT
14.05	5.290 (134.4mm)
14.06	5.915 (150.2mm)
14.75	5.290 (134.4mm)
14.76	5.915 (150.2mm)
14.77	3.110 (79.0mm)
14.91	5.915 (150.2mm)
35.10	1.758 (44.7mm)
35.11	1.758 (44.7mm)
35.12	1.645 (41.8mm)
35.13	1.645 (41.8mm)

HARDWARE SHOWN	
15.31	OPERATOR
30706.92	TRACK
14.05	HINGE
11454.XX	HANDLE

- NOTE:
1. TO DETERMINE THE C DIMENSION, ADD DIMENSIONS X TO HINGE CONSTANT Y TAKEN FROM TABLE . $C = X + Y$
 2. SEE TRUTH TIPS FOR ADDITIONAL HINGE INFORMATION

FIG. 2 ELLIPSE SINGLE ARM WOOD/PVC CUT-OUT DETAIL

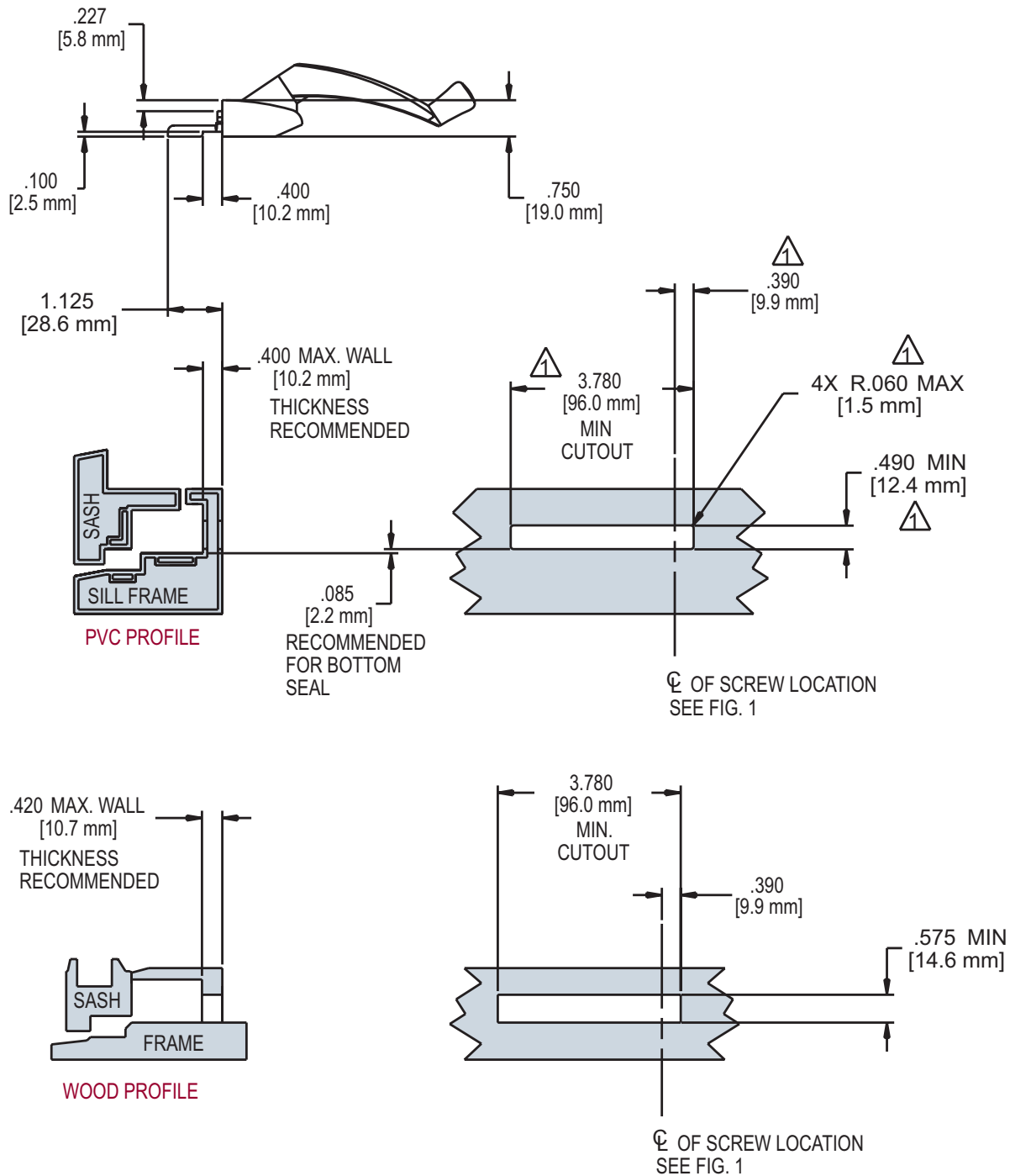

⚠ HOLD THESE DIMENSIONS AS CLOSE TO MINIMUM AS POSSIBLE FOR PROPER GASKET FIT.

FIG. 3 ELLIPSE SINGLE ARM OPERATOR

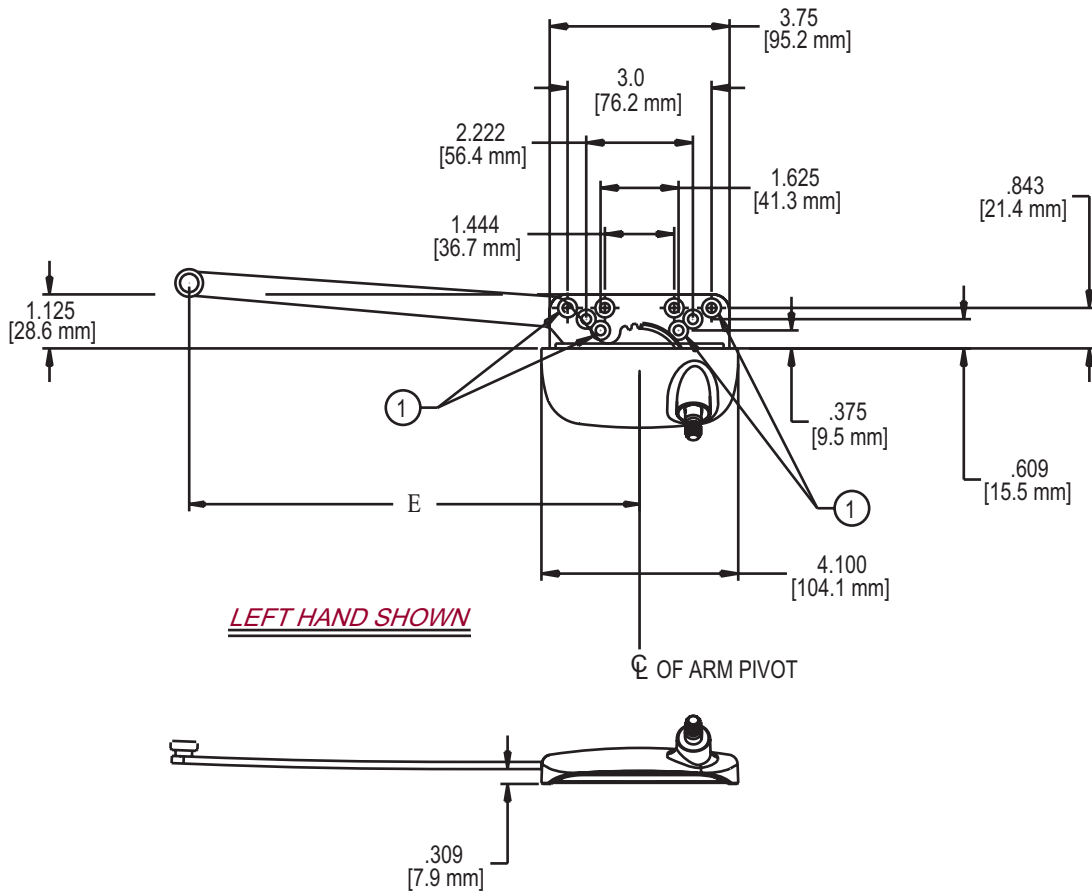

LEFT HAND SHOWN

☉ OF ARM PIVOT

① PREFERRED MOUNTING HOLES (WOOD APPLICATIONS)

RECOMMENDED SCREWS:

WOOD: (QTY 4) (P/N 19380.92) #10 X 1.0 PHILLIPS
FLAT HEAD, SHEET METAL SCREWS

PVC & METAL: (QTY 4) #10 PHILLIPS, FLAT HEAD
SCREWS (LENGTH AND THREAD TYPE
TO BE DETERMINED BY PROFILE)

AVAILABLE OPERATOR	ARM LENGTH E	A SEE FIG. 1	TRACK FOR USE WITH EGRESS HINGE	TRACK FOR USE WITH WASHABILITY HINGE
15.32	13.500 (342.9mm)	15.310 (388.9mm)	30150.92	30706.92
15.31	9.500 (241.3mm)	11.310 (287.3mm)		
15.56	7.500 (190.5mm)	9.310 (236.5mm)	30706.92	NOT RECOMMENDED
15.39	6.0 (152.4mm)	7.810 (198.4mm)	31375.92	

FIG. 4 GASKET APPLICATION FOR ELLIPSE SINGLE ARM OPERATOR

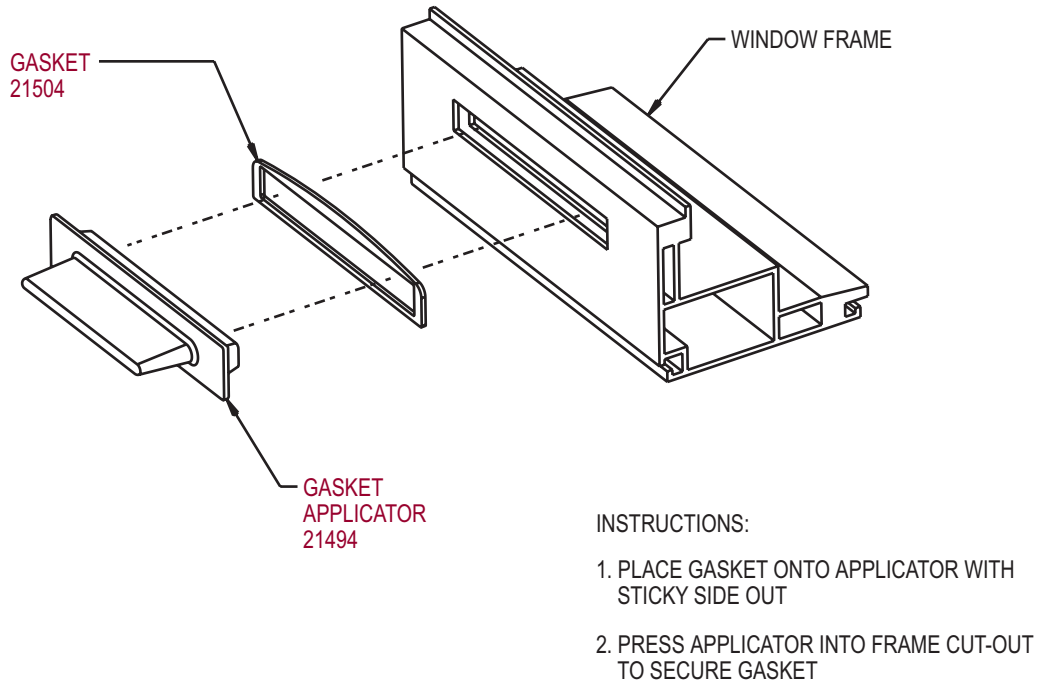
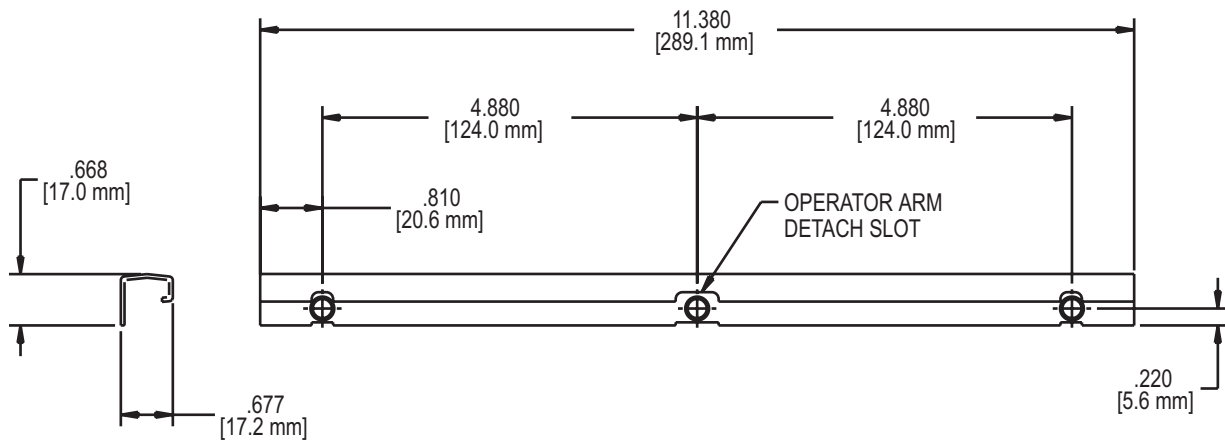

FIG. 5 SINGLE ARM OPERATOR TRACK (3 HOLE) 30706.92



RECOMMENDED SCREWS:

WOOD: (QTY 3) (P/N 19140.92) #7 X .875 PHILLIPS
FLAT HEAD, SHEET METAL SCREWS

PVC & METAL: (QTY 3) #7 PHILLIPS, FLAT HEAD SCREWS
(LENGTH AND THREAD TYPE DETERMINED BY PROFILE)

FIG. 6 SINGLE ARM OPERATOR TRACK (4 HOLE) 30150.92

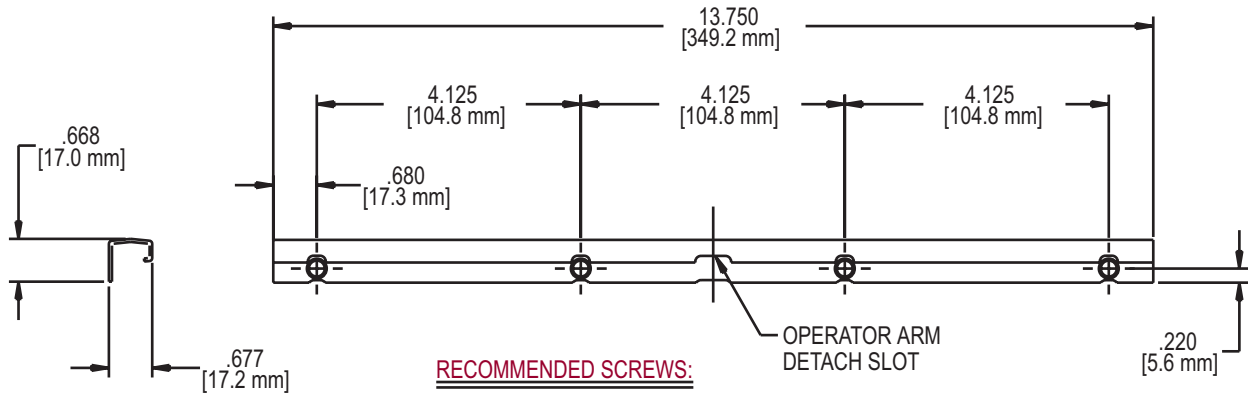

RECOMMENDED SCREWS:

WOOD: (QTY 3) (P/N 19140.92) #7 X .875 PHILLIPS, FLAT HEAD, SHEET METAL SCREWS
 PVC & METAL: (QTY 3) #7 PHILLIPS, FLAT HEAD SCREWS
 (LENGTH AND THREAD TYPE DETERMINED BY PROFILE)

FIG. 7 SINGLE ARM OPERATOR TRACK (3 HOLE) 31375.92

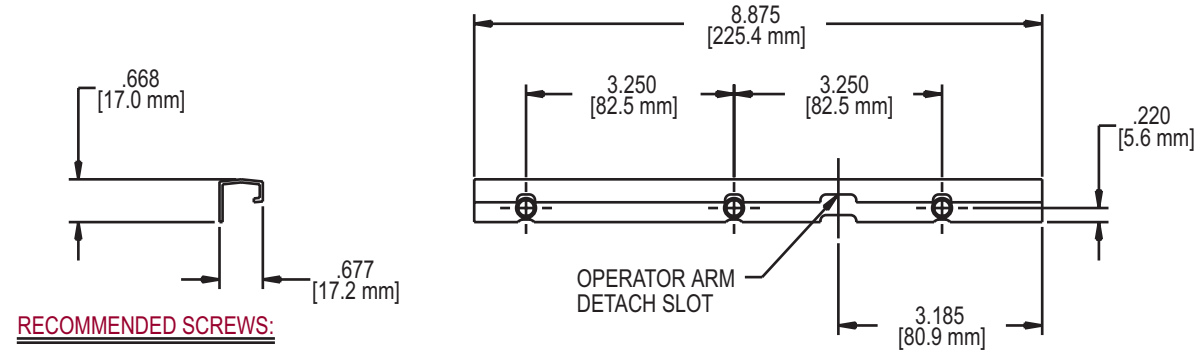

RECOMMENDED SCREWS:

WOOD: (QTY 3) (P/N 19140.92) #7 X .875 PHILLIPS, FLAT HEAD, SHEET METAL SCREWS
 PVC & METAL: (QTY 3) #7 PHILLIPS, FLAT HEAD SCREWS
 (LENGTH AND THREAD TYPE DETERMINED BY PROFILE)

FIG. 8 SINGLE ARM OPERATOR TRACK FOR LIMITED OPENING (4 HOLE) 31727.92

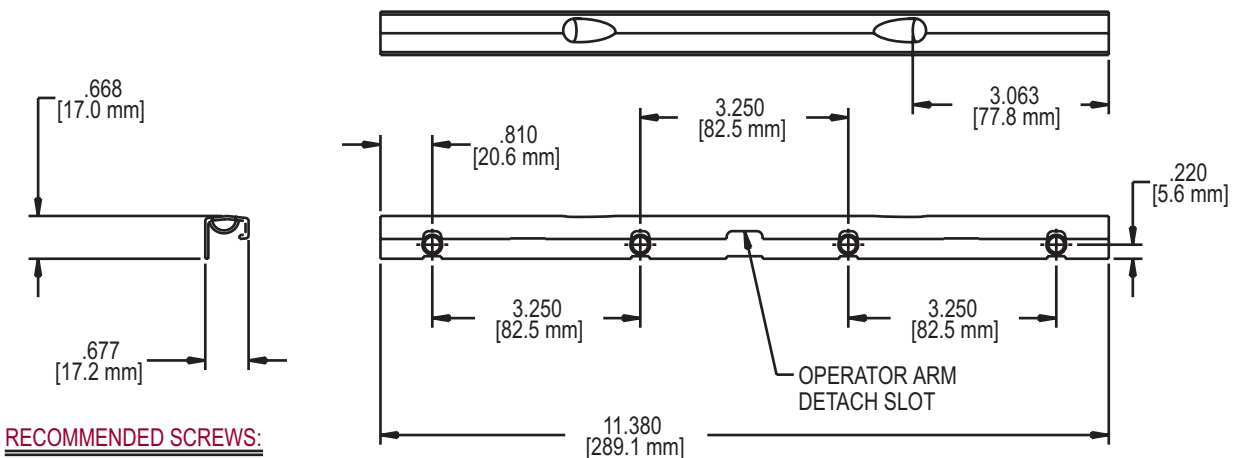

RECOMMENDED SCREWS:

WOOD: (QTY 4) (P/N 19140.92) #7 X .875 PHILLIPS, FLAT HEAD, SHEET METAL SCREWS
 PVC & METAL: (QTY 4) #7 PHILLIPS, FLAT HEAD SCREWS
 (LENGTH AND THREAD TYPE DETERMINED BY PROFILE)



700 WEST BRIDGE STREET, OWATONNA, MN 55060 ■ 507.451.5620 800.866.7884 ■ TRUTH.COM
